

# concept 2 **BikeERG** ASSEMBLY INSTRUCTIONS

## PARTS

\*not to scale

x 16  
3/4" (1.9 cm)  
PN 2233

x 2  
3" (7.62 cm)  
PN 1267

x 1  
3/8" (1 cm)  
PN 1238

x 1  
PN 7030

x 1  
1/2" (1.3 cm)  
PN 2293



T27 6-Lobe Driver

x 1  
3" (7.6 cm)  
PN 1268

x 1  
PN 1271

x 6  
1/2" (1.3 cm)  
PN 1299

x 2  
1" (2.5 cm)  
PN 2276



6 mm Lkey

x 1  
3 1/4" (8.3 cm)  
PN 1224

x 1  
PN 7120

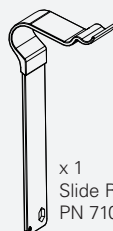

x 1  
Slide Rail/Wrench  
PN 7104

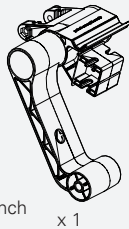

x 1

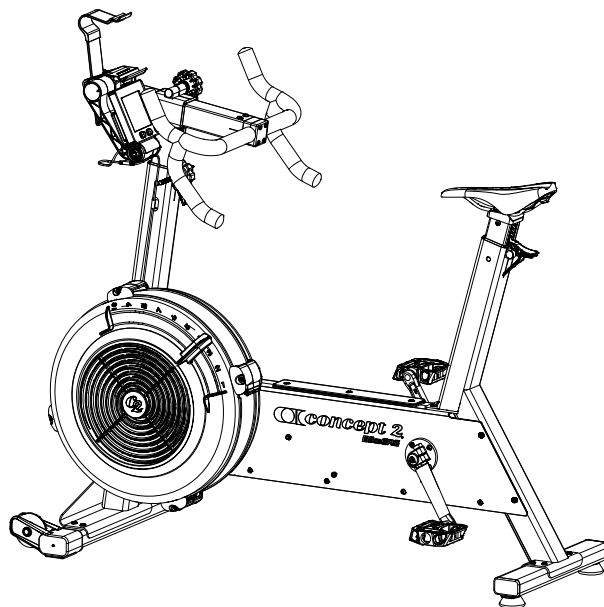

BikeErg weight: 68 lb (31 kg)

Space required for use (training area): 48 in x 60 in (122 cm x 152 cm)

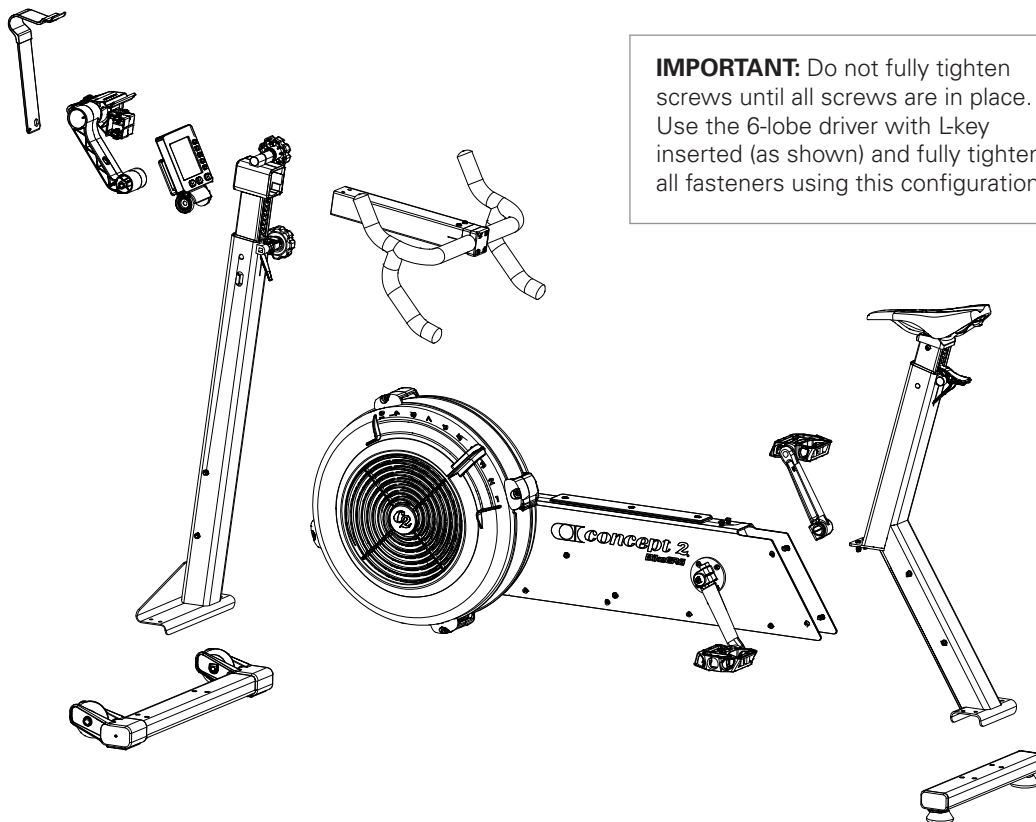

**IMPORTANT:** Do not fully tighten screws until all screws are in place. Use the 6-lobe driver with Lkey inserted (as shown) and fully tighten all fasteners using this configuration.

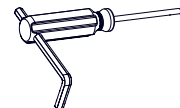

Questions? Comments? Problems?

Contact Concept2 directly at 800.245.5676 (US and Canada)

Or visit us online: [concept2.com](http://concept2.com)

Concept2, Inc. 105 Industrial Park Drive Morrisville, Vermont USA 05661 [concept2.com/contact](http://concept2.com/contact)



1 (4) 3/4" (1.9 cm)  
PN 2233

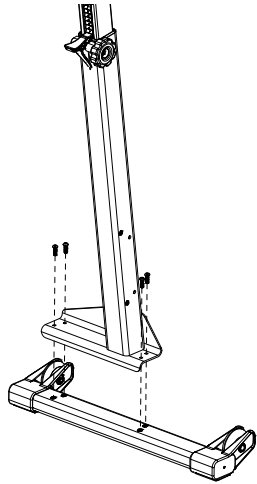

2 (4) 3/4" (1.9 cm)  
PN 2233

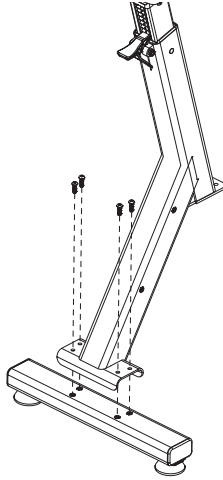

3 (6) 3/4" (1.9 cm)  
PN 2233

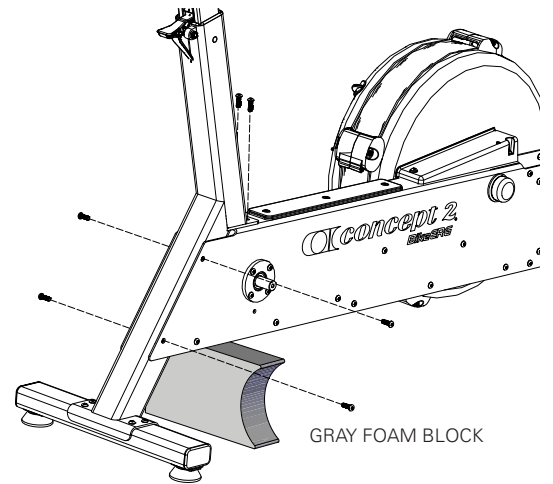

4

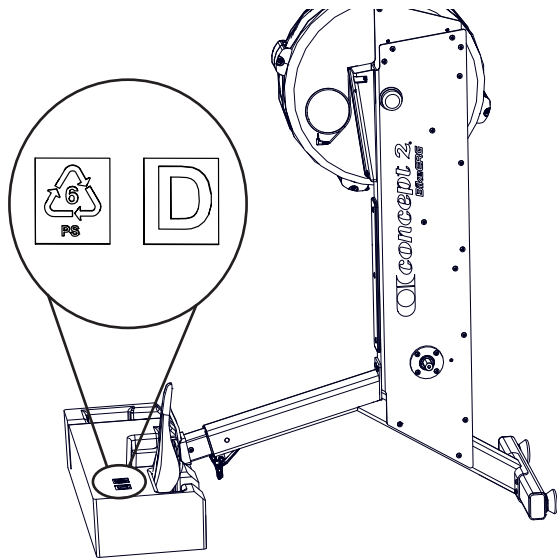

5

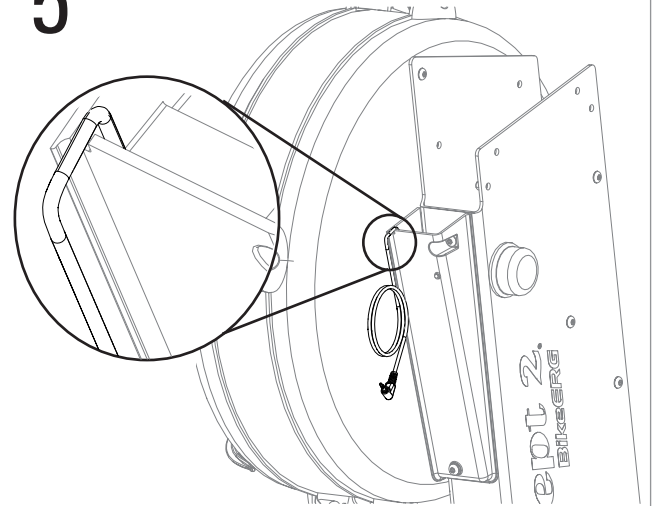

6 (2) 3/4" (1.9 cm)  
PN 2233

(2) 3" (7.62 cm)  
PN 1267

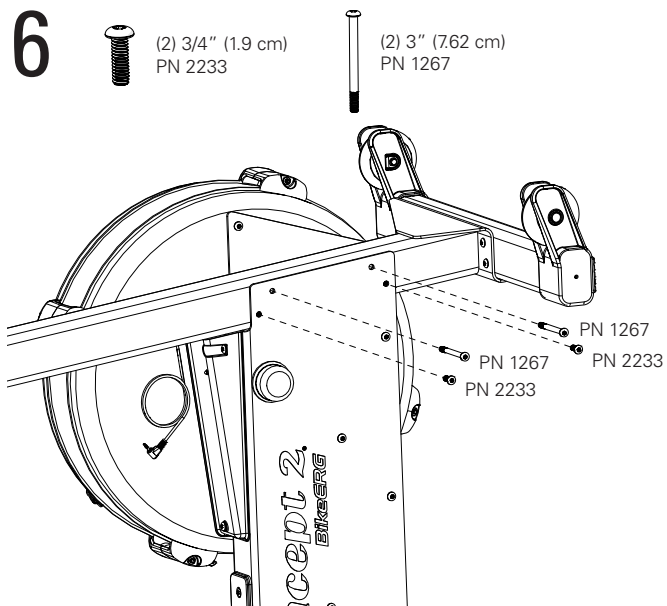

7

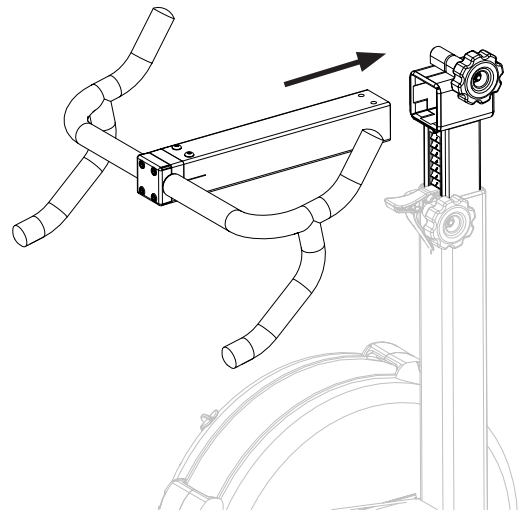

8

(4) 1/2" (1.3 cm)  
PN 1299

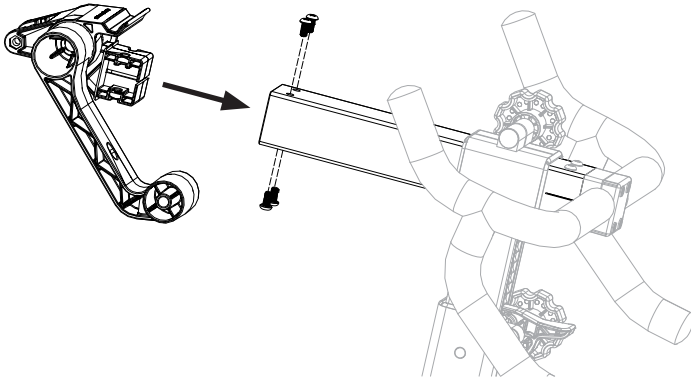

9

(1) 3" (7.6 cm)  
PN 1268

(1) PN 1271

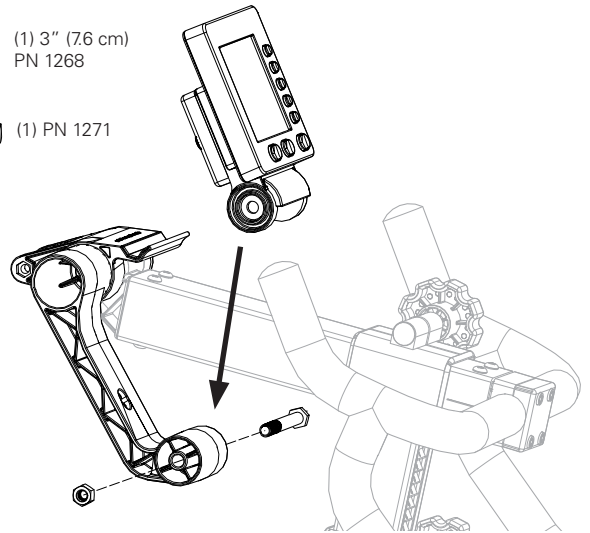

10

PN 7104

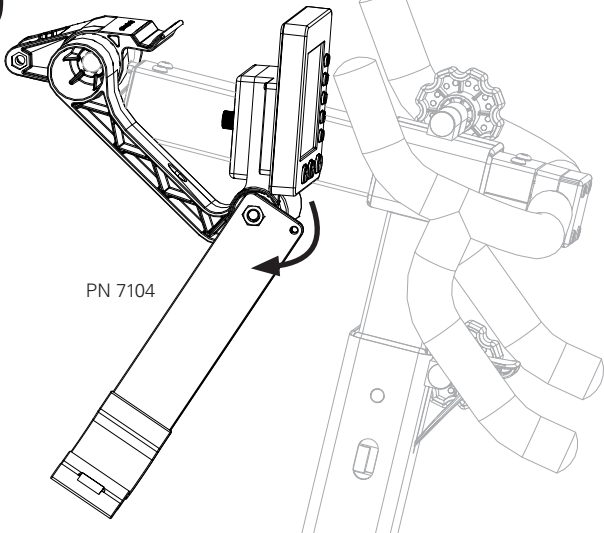

11

(2) 1/2" (1.3 cm)  
PN 1299

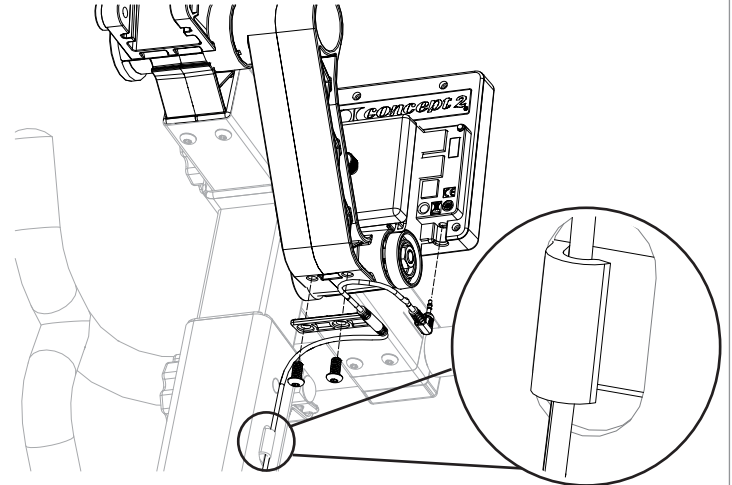

12

PN 7104

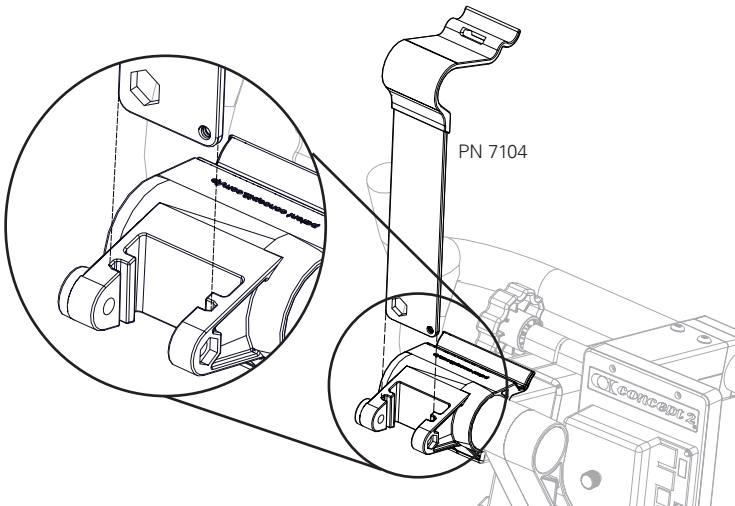

13

(1) 3 1/4" (8.3 cm)  
PN 1224

(1) PN 7120

(1) 3/8" (1 cm)  
PN 1238

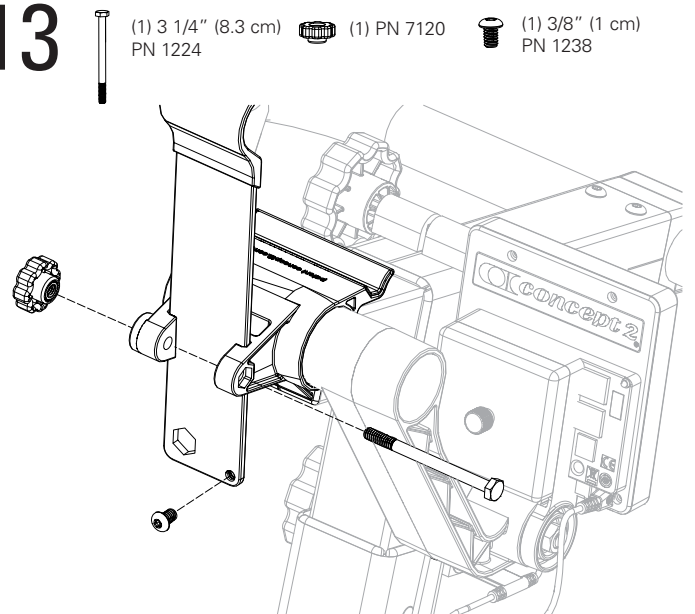

# 14



(1) 1/2" (1.3 cm)  
PN 2293



(1) PN 7030

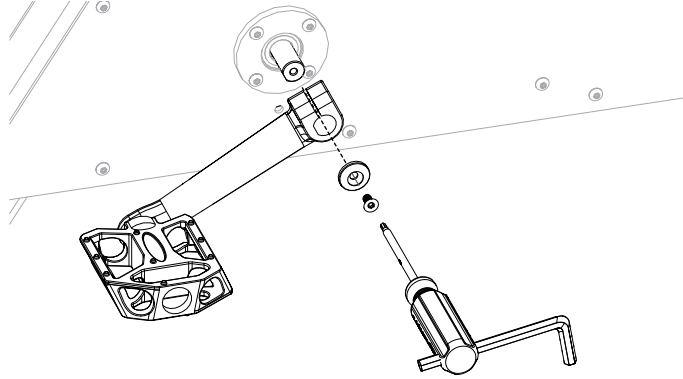

# 15



(2) 1" (2.5 cm)  
PN 2276

**Note:** Alternate tightening the fasteners 3 times each.

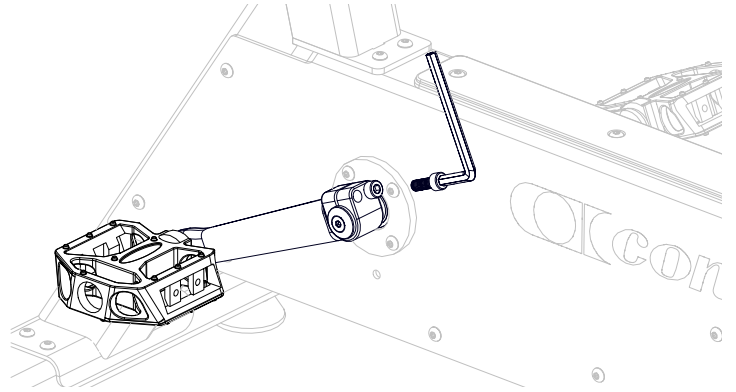

# 16

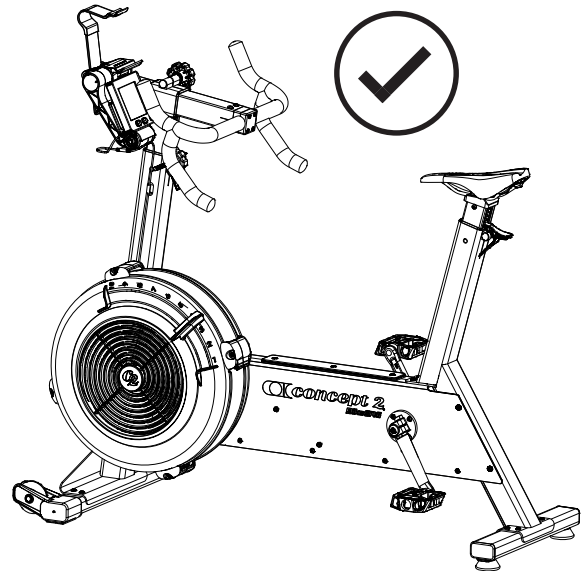
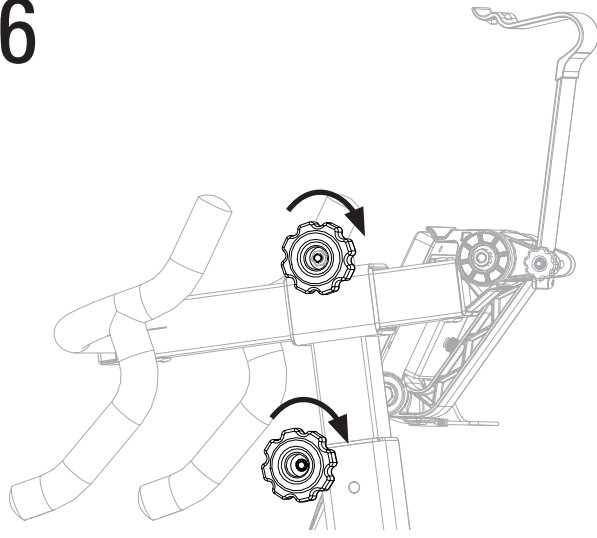

## How to Use the Device Holder

Insert device

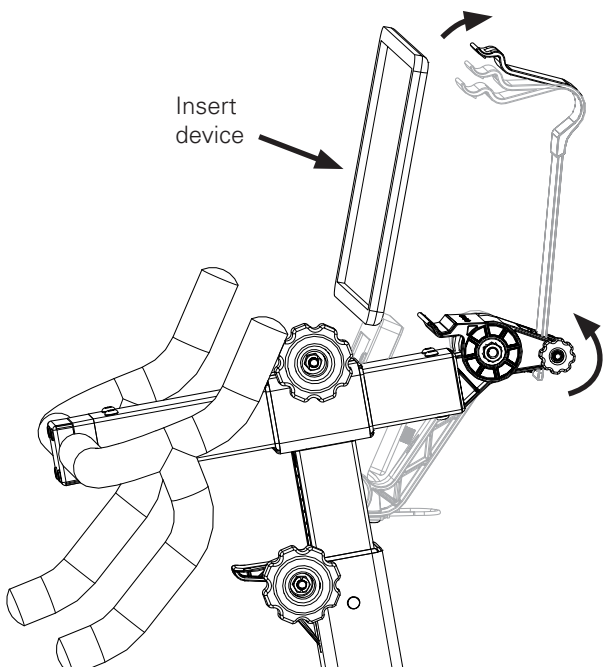

Download our **FREE**  
**ErgData** app for:

- Workouts
- More data displays
- Real time rowing with the Concept2 community

[concept2.com/ergdata](http://concept2.com/ergdata)

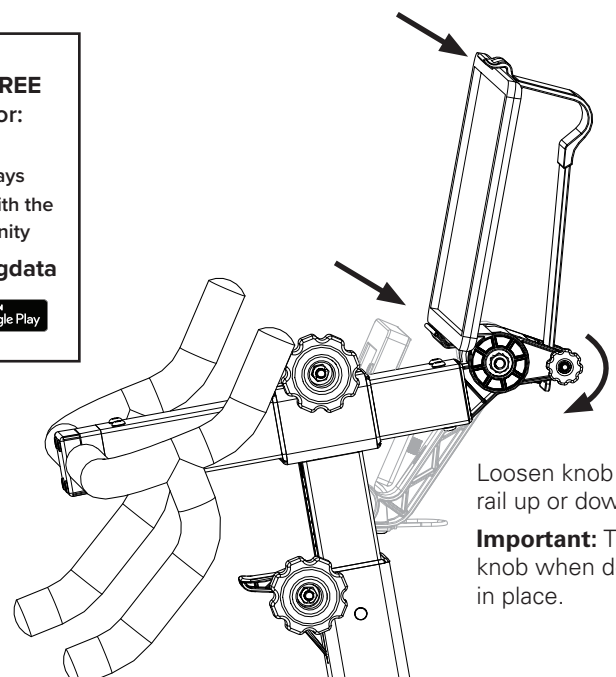

Loosen knob to slide rail up or down.

**Important:** Tighten knob when device is in place.